

II B. Tech I Semester Supplementary Examinations, May/June - 2016
MECHANICS OF SOLIDS
 (Com. to ME, AME, AE, MTE)

Time: 3 hours

Max. Marks: 70

- Note: 1. Question Paper consists of two parts (**Part-A** and **Part-B**)
 2. Answer **ALL** the question in **Part-A**
 3. Answer any **THREE** Questions from **Part-B**

PART -A

1. a) Define the terms factor of safety and poissons ratio? (4M)
- b) Explain about the Point of contra flexure (3M)
- c) Write the Section modulus formulae for Rectangular section and Hollow Rectangular Section? (4M)
- d) Explain about Statically Indeterminate Beams? (3M)
- e) Derive the formula for longitudinal and circumferential stresses in thin cylinders. (4M)
- f) Write about the limitations of Euler's Formula (4M)

PART -B

2. a) A composite bar consisting of three segments as shown in figure: 1 is rigidly connected at their ends. If the composite member is subjected to a longitudinal pull of 120 kN, estimate the proportion of load carried by each rod and the induced stresses. (8M)

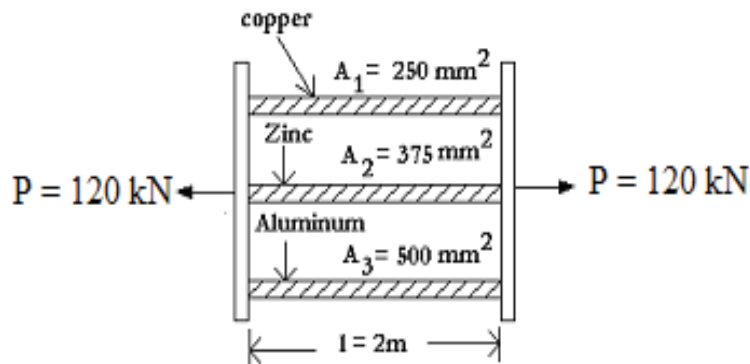

Figure 1

Take $E_{\text{cu}} = 130\text{ GN/m}^2$: $E_{\text{zinc}} = 100\text{ GN/m}^2$: $E_{\text{al}} = 80\text{ GN/m}^2$

- b) A hollow cylinder of internal and external diameters of 12.5 cm and 25 cm and a length of 50 cm is stressed to 840 N/mm^2 by an axial load. The modulus of Elasticity of the material is $2 \times 10^5\text{ N/mm}^2$, while its Poisson's ratio is 0.25. Find the change in i) its internal dimensions ii) change of internal volume (8M)

3. a) A cantilever beam of 6m span carries a load, which varies from zero at the fixed end to 2 kN/m run at midspan and decreases to zero at the free end. Draw SFD and BMD. (8M)
- b) Develop Bending moment and Shear force for the Figure 2 given below (8M) indicating the maximum and minimum values.

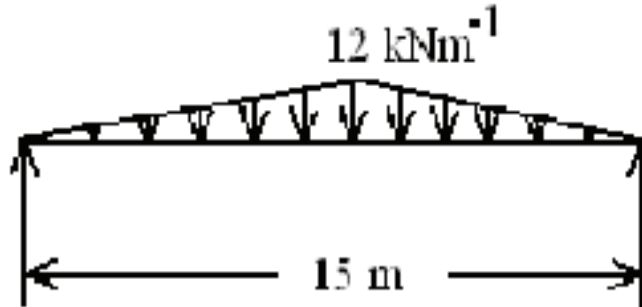

Figure: 2

4. a) A rectangular beam 125mm wide is subjected to maximum shear force of 110kN. Find the depth of the beam if the maximum permissible shear stress is 7Pa. (8M)
- b) A beam of I-section is having overall depth of 700mm and overall width as 230mm. The thickness of the flanges is 25mm where as the thickness of the web is 20mm. If the section carries a shear force of 64kN, Calculate the shear stress at salient points. (8M)
5. A simply supported beam AB of span 5 meters is carrying a point load of 30 kN at a distance 3.75 m from the left end A. Calculate the slopes at A and B deflection under the load. Take $EI=26 \times 10^{12} \text{ N-mm}^2$. (16M)
6. A Compound cylinder comprises an inner tube of diameters 100.0 mm and 140.0 mm, and an outer tube of diameters 140.0 mm and 180.0 mm. Determine the diametral interference required so that the final maximum stress in the tube does not exceed 120.0 MPa under an internal pressure of 45.0 MPa. Neglect the effects of longitudinal stresses. Assume $E = 120.0 \text{ GPa}$. (16M)
7. a) A hollow shaft of 60 mm outer diameter transmits 180 kW of power while rotating at a frequency of 25 hertz. Find the thickness of the shaft so that the shear stress does not exceed 60 N/mm^2 . (8M)
- b) Explain about Columns with Pinned ends and write about Rankine's Formula? (8M)
